

# INSTRUCTION MANUAL

## Battery-operated hydraulic Cutting Tool

### CutMax 4



<p>Translation of the original instruction manual                  Ident-No.: 72624000-BA                  Edition: 03/2015                  Revision: F</p>	<p>HOLGER CLASEN GmbH &amp; Co. KG                  Alsterdorfer Straße 234                  DE-22297 Hamburg</p>	<p>Tel. +49 (0)40 – 511 28-0                  Fax +49 (0)40 – 511 28-111                  Info@Holger-Clasen.de                  www.Holger-Clasen.de</p>
--	---	---

# Content

<b>1</b>	<b>General Information .....</b>	<b>3</b>
<b>2</b>	<b>General Safety Information.....</b>	<b>5</b>
<b>3</b>	<b>Product Description .....</b>	<b>6</b>
<b>3.1</b>	<b>Intended Use .....</b>	<b>6</b>
<b>3.2</b>	<b>Expected misuse .....</b>	<b>6</b>
<b>3.3</b>	<b>Qualification .....</b>	<b>7</b>
<b>3.4</b>	<b>Operator Protection.....</b>	<b>7</b>
<b>3.5</b>	<b>Work Place .....</b>	<b>7</b>
<b>3.6</b>	<b>Transport and Storage .....</b>	<b>7</b>
<b>4</b>	<b>Technical Data .....</b>	<b>8</b>
<b>4.1</b>	<b>Cutting Range Table.....</b>	<b>9</b>
<b>5</b>	<b>Commissioning .....</b>	<b>10</b>
<b>6</b>	<b>Operation .....</b>	<b>12</b>
<b>6.1</b>	<b>Inserting / Removing the Battery .....</b>	<b>12</b>
<b>6.2</b>	<b>Cutting.....</b>	<b>13</b>
<b>6.3</b>	<b>Functional Monitoring ELWA® basic .....</b>	<b>15</b>
<b>7</b>	<b>Trouble-shooting .....</b>	<b>16</b>
<b>8</b>	<b>Maintenance and Service.....</b>	<b>17</b>
<b>9</b>	<b>Disposal.....</b>	<b>18</b>
<b>10</b>	<b>Accessories .....</b>	<b>19</b>
<b>11</b>	<b>Drawing.....</b>	<b>20</b>
<b>12</b>	<b>Part List .....</b>	<b>21</b>
<b>13</b>	<b>Declaration of Conformity.....</b>	<b>24</b>

# 1 General Information

We hereby confirm that the tool described in this instruction manual complies with the basic safety and health requirements pursuant to the EC Machinery Directive 2006/42/EC, the EMC Directive 2014/30/EU and the RoHS Directive 2011/65/EU.

Keep this instruction manual in a place that all users of the tool are familiar with and can access easily. Read this manual carefully before using, maintaining, repairing or disposing of the tool. Make sure that you clearly understand the instructions and symbols explained in this manual or attached to any tools.

You can prevent accidents by adhering to the following basic safety advice pursuant to the EC Machinery Directive 2006/42/EC and the regulations for hand-operated tools. In any case inform yourself about and comply with the accident prevention regulations applicable in your country.

Do not remove existing labels and stickers, especially those containing legally required information.

Upon receiving the tool, make sure that the packaging is intact and the tool did not suffer any transportation damage. In case of damage, please contact HOLGER CLASEN's customer service at +49 (0) 40 511 28-0. Keep the packaging.

If operated correctly and if the required service intervals are adhered to, we grant a warranty of 24 months beginning as of the day of delivery unless legal regulations require other warranties.

## Symbols used:



WARNING!



Danger of hand injuries



Please wear safety goggles



Please wear safety shoes



Please wear protective clothes



Don't dispose of in residual waste

## Directives and norms used:

DIN EN 60745-1:2009+A1:2010;

DIN EN 60745-2-8:2009

DIN EN 61000-6-4:2007+A1:2011

DIN EN 61000-6-2:2005

2006/42/EU Machinery Directive

2014/30/EU EMC Directive

2011/65/EU RoHs Directive

## Label:

Danger of hand injuries

Type label (manufacturer, CE, built, type designation, cutting force, max. cutting range); Label

ELWA® basic

Serial No.: punched at the cutting head

## 2 General Safety Information

### WARNING

#### **Hydraulic fluid under pressure.**

Escaping fluid under pressure can cause severe injury or death.

- ▶ If injured, seek medical attention immediately.

#### **Electric Shock.**

The tool is not insulated in contact with electrically charged parts.

- ▶ Never work live strands / cables!

#### **Exposed Cutting Blades.**

Danger of hand injuries.

- ▶ Never reach into the running tool.

Do not use the tool in an environment prone to fire or explosion hazards.

Keep out of reach of children and unauthorized persons.

Do not operate the tool in a way that may compromise safety.

Attachments and accessories may only be used for the intended work.

Do not modify or change the tool.

Before switching on the tool, make sure that no one may be injured by the starting tool.

Make sure to work in a comfortable position.

## 3 Product Description

- 1 Lash for Carrying Strap
- 2 LED ELWA® *basic*
- 3 Cutting Head, rotatable by 180°
- 4 Safety Bolt
- 5 Counter Blade
- 6 Cutting Blade
- 7 Release Button
- 8 Return Button
- 9 LED Work Field Illumination
- 10 Accumulator  
(only included in the Set)
- 11 Locking Button Accumulator
- 12 Lash for Carrying Strap



### 3.1 Intended Use

This battery-operated hydraulic tool has been designed for cutting Cu- and Al-strand/cable up to  $\varnothing$  42 mm as well as ACSR (overhead lines), round material and round steel according to the application table (chapter 4.1). For other applications, please contact HOLGER CLASEN. The tool has been designed to be connected to an accumulator HOLGER CLASEN, 14.4 V.

Although this tool has been designed according to the state-of-the-art and recognized safety requirements, its use may constitute a potential threat to the life and limbs of its user or third parties or damage the tool or other material assets. Use or application for purposes other than those intended by the manufacturer will be considered improper. HOLGER CLASEN will not be liable for damage resulting from improper use. The operator works at his own risk.

### 3.2 Expected misuse

**This tool is not suitable for cutting high-tensile or hardened steel, which will damage and possibly break the knife. This tool is not suitable for cutting fine/very fine stranded conductors, this will cause the blades to jam.**

### 3.3 Qualification

This tool may only be used by qualified personnel who have read this safety advice and instruction manual.

### 3.4 Operator Protection



**Danger due to chips flying around.**

Wear protective goggles.

Standard glasses do not provide sufficient protection and are no proper substitution for safety eyewear.



**Danger of drawing in of clothes and hair.**

Wear protective clothes.

Loose or baggy clothes increase the risk of catching or winding on moving parts.

- Wear tight-fitting work clothing.
- Do not wear long hair open. Wear it well covered.
- Do not wear rings, chains or other jewellery.



**Risk of crushing/sliding.**

Wear protective shoes.

Make sure to stand firmly.

### 3.5 Workplace

Make sure you have a suitable working environment.

Do not expose the tool to moisture.

Ensure adequate lighting at the workplace.

Protect the tool from moisture, water, extreme heat/cold, chemical solutions and gases.

If the tool is colder than  $-5^{\circ}\text{C}$ , store it for at least one hour in a room with a temperature of  $+10$  to  $+25^{\circ}\text{C}$ , in order to remove the tool to room temperature again.

Protect the battery tool from falls or impacts.

### 3.6 Transport and Storage

Ensure dry storage to protect the tool from rust.

Clean the tool before / after use and before storage.

Secure the contact surfaces of the battery with the cover provided.

If the tool is transported to another factory department or location, make sure that the tool and/or accessories are not damaged. Pack the tool accordingly.

Notice IATA Packing instruction 965 Part 2 for lithium-ion-batteries. If package/battery is damaged, batteries must be quarantined, inspected and repacked.

**Attention: Following the IATA Packing instructions the batteries are delivered on 30 % charge level. Please completely charge the battery before usage with the recommended battery charger.**

## 4 Technical Data







Item	CutMax 4
Cutting Force	70 kN
Opening Width	42 mm
Battery Voltage	14.4 V
Weight*	5.6 kg
Dimensions* L x W x H	460 x 80 x 292 mm
Item No. Set	72624000

\* without battery

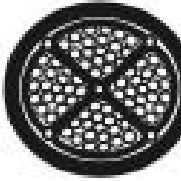
### Scope of Delivery:

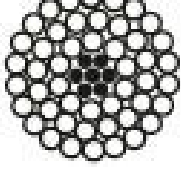
Battery-operated hydraulic Cutting Tool CutMax 4 (Item No. 72614000),  
 2 Lithium-Ion Batteries IPP-40, 14.4 V / 4Ah (Item No. 79300125),  
 Battery Charger IMC-2 (AC) (Item No. 79300130),  
 Carrying Strap TR-REC (Item No. 07542106),  
 Transportation Case Koff-K CM34 (Item No. 79500073)

## 4.1 Cutting Range Table

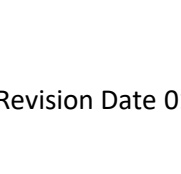
Anwendung <i>Application</i>	Max. Schneiddurchmesser <i>Max. Cutting Diameter</i>	
Cu Seil <i>Cu Strand</i>	Ø 42 mm	
Al Seil <i>Al Strand</i>	Ø 42 mm	
Cu Energiekabel <i>Cu Energy Cable</i>	Ø 42 mm	
Al Energiekabel <i>Al Energy Cable</i>	Ø 42 mm	
Cu Rundmaterial <i>Cu Round Material</i>	Ø 20 mm	
Al Rundmaterial <i>Al Round Material</i>	Ø 22 mm	
Al/St-Seil <i>ACSR</i>	Ø 38 mm (St-Anteil/part: 79 mm <sup>2</sup> , 450/40)	
Rundstahl <i>Round Steel</i>	Ø 20 mm	
Drahtseil <i>Wire Rope</i>	6x7: Ø 22 mm 6x12: Ø 22 mm 6x19: Ø 22 mm	
Abspanndraht <i>Guy Wire</i>	1x17: Ø 15 mm 1x19: Ø 20 mm	

## 5 Commissioning

The scope of delivery of the tool set consists of a tool, a HOLGER CLASEN lithium-ion battery IPP-40, 14.4 V, and a matching charger IMC-2 (AC). Fully charge the battery before first use.

Make sure the battery is fully charged before each use.

The LEDs provide information about the battery capacity.

Press the test button on the battery.



Battery charge level indicator:

■ ■ ■	70 % - 100 %
■ ■ □	30 % - 70 %
■ □ □	5 % - 30 %
□ □ □	0 % - 5 %

The scope of delivery of the chargers consists of a power supply unit (12 - 24 V DC or 100 - 240 V AC) and a charging tray. These must be connected together before use.

### Charging the battery with the IMC-2 (AC) charger:

Insert the mains plug of the AC adapter into a socket with 100 - 240 V AC / 50 - 60 Hz. Place the battery firmly in the holder of the charger. Charging is only possible in one position. For charging times, please refer to the technical data in the accessories, chapter 10.

### Charging the battery with the IMC-2 (DC) charger:

Insert the mains plug of the mains adapter into a car socket with 12 - 24 V DC. Insert the battery firmly into the charger holder. Charging is only possible in one position. For charging times, please refer to the technical data in the accessories, chapter 10.



**ATTENTION!**

With the lithium-ion battery, the battery is optimization of the charging process calibrated.

Charger display:



LED-Display		Meaning
	NO Shining	Charger is ready for use.
	GREEN shines	Battery is recharging.
	ORANGE shines	Battery is fully charged.
	RED shines	Temperature warning - Environment is too hot or too cold. - Tool is too hot or too cold. Leave the battery in the charging slot until the right temperature has been reached and charging is possible.
	RED blinks	Battery and charger are not compatible.

## 6 Operation

### **⚠ WARNING**

#### **Exposed Cutting Blades.**

Danger of hand injuries.

- ▶ Never reach into the running tool.

Overheating of the motor is possible after continuous operation.  
Allow the tool to cool down in good time for a few minutes.

### 6.1 Inserting / Removing the Battery

The LEDs indicate the battery capacity.  
To do this, press the test button on the battery.



#### **Inserting:**

Push the tool firmly onto the battery until the locking button engages.  
Check that the battery is firmly engaged.

#### **Removing:**

Press and hold the locking button.  
Pull the battery off the tool.

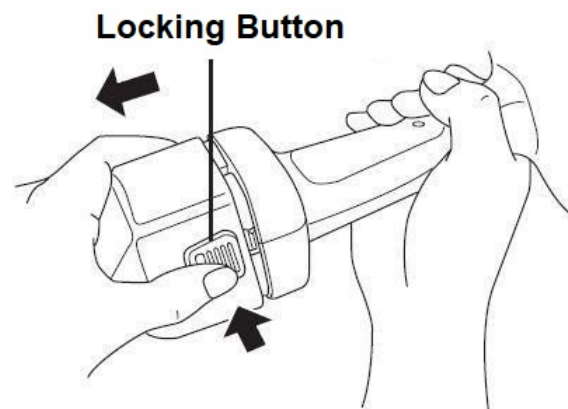

## 6.2 Cutting

Check the head and the control buttons for function and damage.

If there is obvious damage, do not put it into operation.

### Move the cutting blade back:

Bring the cutting blade back to its original position before cutting. To do this, operate the return button (8).



### Move the cutting blade forward:

For safety reasons, the forward button (7) has a lever lock. Push up the lever lock. Advance the cutting blade by operating the forward button (7).

### Open the Cutting Blade:

Pull the safety bolt out of the cutting head, the counter blade folds down.

Position the material to be cut.

Fold back the counter blade. Insert the locking bolt completely back into the cutting head.

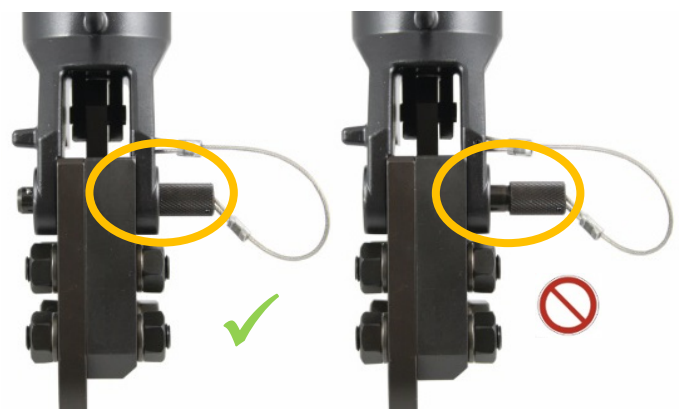

### Locking properly

Make sure that the locking unit is closed completely. Non-observance will lead to deformation and even destruction of the head.

 **NOTICE**

Non-observance of the following advices will lead to damage and even to breakage of the blades.

**Alignment of the tool to cable:**

Position the tool so that it cuts axial to the cable.



**Cutting:**

Press the release button (7) to cut the cable.

Keep the release button pressed until the cable is cut completely.



Bring the cutting blade back to its original position by operating the return button (8).



Remove any chips and metal left on the brush and blade before cutting again.

### 6.3 Functional Monitoring ELWA<sup>®</sup> basic

The ELWA<sup>®</sup> basic function control is not relevant for controlling the cutting cycle.

In usage the tool will not reach the max. cutting force because cutting is previously successful (LED blinks red 10 times after cut).

**The ELWA<sup>®</sup> basic may be used for indicating the condition of the tool and the battery (without inserted material):**

LED-Display	Trigger	Description	Cause and Result
 green	Trigger pressed	Tool reaches max. cutting force	Tool ready to use ▶ good battery capacity
 red	Trigger pressed	Tool reaches max. cutting force ▶ but only less cutting cycles possible	Low battery, only 30 - 40% capacity ▶ recharge battery soon
 red 10 x 0.5 sec.	After releasing trigger	Max. cutting force cannot be reached	Battery empty ▶ replace / recharge battery  Tool / battery to cold ▶ warm up tool / battery

## 7 Trouble-shooting

Error	Cause	Solution
The tool does not work.	The battery is not charged.	Recharge the battery.
	The battery is not inserted correctly.	Insert the battery correctly.
	The contacts between the battery and the tool are dirty.	Clean the contacts.
	Fault in the hydraulic system (e.g. air).	Have the manufacturer inspect the tool.
The blades do not move forward or back.	The blades are dirty.	Remove chips and metal left on the blades.
	The blades and the material to be cut are twisted.	Have the manufacturer inspect the tool.
	Wear of the return spring.	Have the manufacturer inspect the tool.
Material is not cut.	Check the application / the material to be cut.	Wrong application.
	The material to be cut is too cold. *	Warm up the material to be cut.

\* At temperatures below 10° C, the cutting properties of electrical conductors change. Cuts may not be possible even if they are within the range of intended use.

## 8 Maintenance and Service

Task	Period	Maintenance by
Clean and grease the blades from dirt to avoid damage of the tool. Do not use chemicals, water or wet clothes.	After each use	User
Inspect the movable parts regularly for damage.	Daily	User
Maintenance of the tool.	Every 12 months (approx. 10.000 work cycles)	HOLGER CLASEN

If the tool is colder than -5°C, store it for at least one hour in a room with a temperature of +10 to +25°C, in order to remove the tool to room temperature again.

Disassembly or modification of the tool by unqualified persons could cause accidents. Always allow qualified technicians only or the HOLGER CLASEN Technical Service Center (TSC) to carry out maintenance work. Use original spare parts by HOLGER CLASEN.

### Service address:

The TSC will do all required maintenance and repair work for you.



TSC Technik-Service-Center  
 Alsterdorfer Straße 234, DE-22297 Hamburg  
 Tel. +49 (0)40 – 511 28-0, Fax +49 (0)40 – 511 28-315  
[service@Holger-Clasen.de](mailto:service@Holger-Clasen.de)  
[www.Holger-Clasen.de](http://www.Holger-Clasen.de)

## 9 Disposal



**The tool must not be disposed of as residual waste because some parts of the tool may cause environmental damage! Improper disposal constitutes a punishable offence according to the Environmental Liability Act!**

The battery, the circuit boards and other components must be disposed of separately in accordance with the environmental standards in force in the European Union or in your country. Send the tool to HOLGER CLASEN for disposal.

# 10 Accessories

Type		Description	Item No.
Case	Koff-K CM34	Lightweight Plastic case with compartments for tool, two batteries and battery charger	79500073
Carrying Strap	TR-REC	Carrying strap for battery-operated tools, strap 25 mm wide, 1 snap hook	07542106
Carrying Strap	TR-25-2	Carrying strap for battery tools, strap 25 mm wide, 2 snap hooks	07755001
Spare Blade	40-14	Cutting Blade	07448106
Spare Blade	400-30	Counter Blade	07173224
Lithium-Ion Battery	IPP-40	Battery Voltage: 14.4 V Capacity: 4.0 Ah Weight: 0.56 kg Charger: IMC-2, IMC-1 Charging Time: 70 min ( $\pm$ 80 %) 90 min ( $\pm$ 100 %)	79300125
Battery Charger	IMC-2 (AC)	Input Voltage: 100 – 240 V, 50/60 Hz Weight: 0.64 kg Charging Time IPP-40: 70 min ( $\pm$ 80 %) 90 min ( $\pm$ 100 %)	79300130
Car Charger	IMC-2 (DC)	Input Voltage: 12 – 24 V, Car socket Weight: 0.64 kg Charging Time IPP-40: 70 min ( $\pm$ 80 %) 90 min ( $\pm$ 100 %)	79300131
Power Supply Unit	NT-Hyk	Input Voltage: 230 V AC / 50 Hz Output Voltage: 14.4 V Switch-on Time: 33 %, 5 min / 15 min Temperature Range: +5° up to 45° C Protection Class: II, IP30 Dimensions: 120 x 72 x 120 mm Weight: 0.95 kg (cable included) Cable length: 5 m	79300060

# 11 Drawing

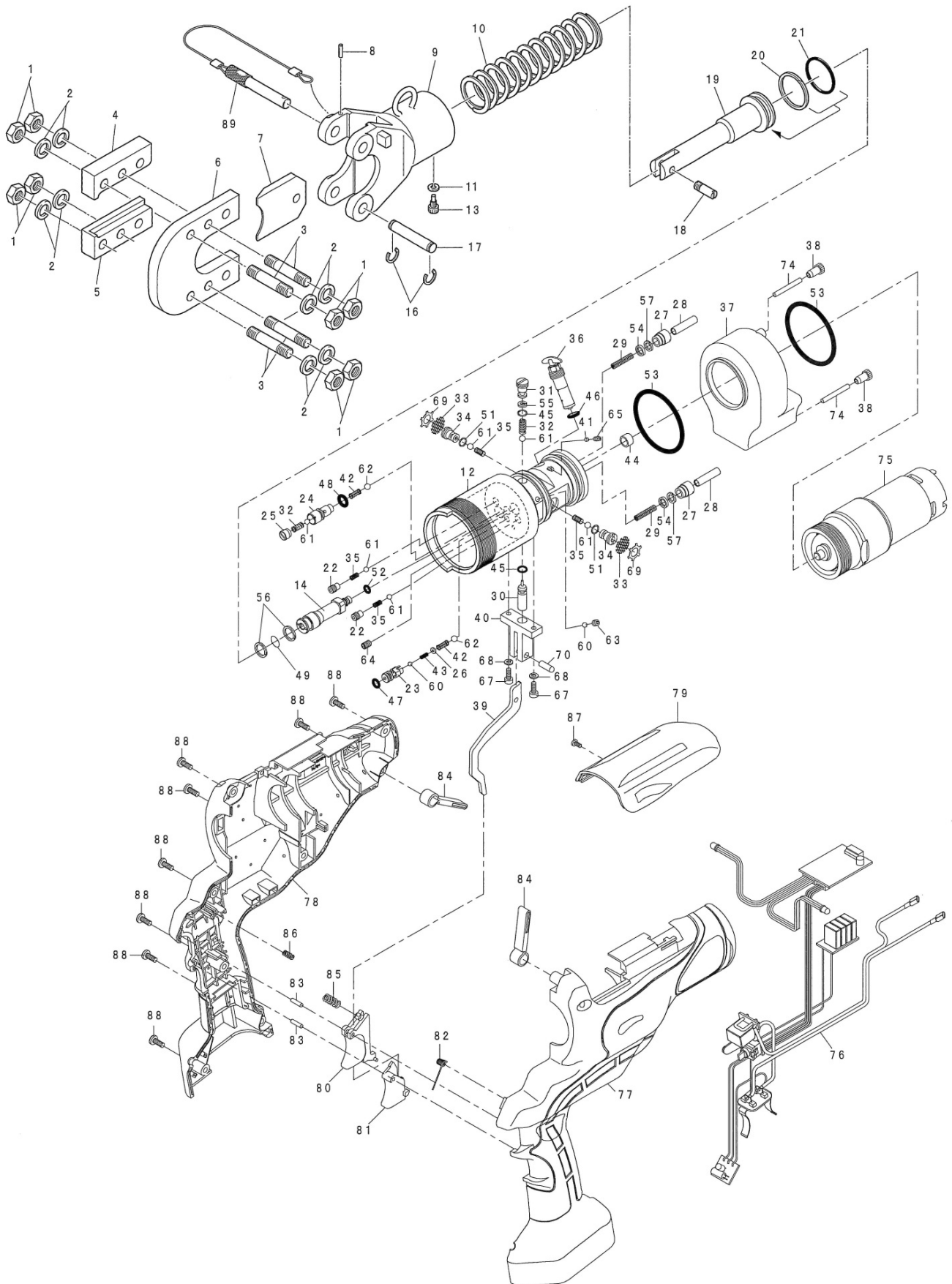

# 12 Part List

Position	Item No.	Description	Pcs.
1	07329114	Nut	8
2	07131107	Spring Washer	8
3	07066273	Pin	4
4	07321237	Blade Liner	1
5	07321238	Blade Liner	1
6	07173224	Head Shear	1
7	07448106	Blade	1
8	07066110	Pin	1
9	07652230	Cylinder Head	1
10	07123510	Spring	1
11	07417145	Washer	1
12	07175009	Housing	1
13	07452230	Screw	1
14	07267016	Inner Pipe	1
16	07472136	Cerclip	2
17	07066272	Pin	1
18	07322102	Blade Screw	1
19	07267004	Piston	1
20	07535261	Backup Ring	1
21	07358460	O-Ring	1
22	07585002	Valve Screw	2
23	07559002	Both-way plug	1
24	07559001	LP control plug	1
25	07585001	Valve Screw	1
26	07532001	Stopper Ring	1
27	07593226	Valve Cap	2
28	07371224	Piston	2
29	07123662	Spring	2
30	07055002	Reaction Pin	1
31	07530250	Plug	1
32	07123664	Spring	2
33	07136002	Filter	2
34	07559293	Valve	2
35	07123663	Spring	4
36	07546005	Relief Valve	1

Position	Item No.	Description	Pcs.
37	07351005	Oil Reservoir	1
38	07530001	Plug	2
39	07053002	Release Lever	1
40	07212001	Holder	1
41	07044001	Retainer	1
42	07123665	Spring	2
43	07123005	Spring	1
44	07068346	Bush	1
45	07358186	O-Ring	2
46	07358351	O-Ring	1
47	07358242	O-Ring	1
48	07358189	O-Ring	1
49	07358010	O-Ring	1
51	07358698	O-Ring	2
52	07358008	O-Ring	1
53	07358009	O-Ring	2
54	07081344	Seal Packing	2
55	07535152	Backup Ring	1
56	07535012	Backup Ring	2
57	07358240	Backup Ring	2
60	07506101	Steel Ball	2
61	07277123	Ball	6
62	07277122	Ball	2
63	07452254	Screw	1
64	07525124	Plug	1
65	07452788	Screw	1
67	07452018	Screw	2
68	01132109	Spring Washer	2
69	07386322	Ring	2
70	07524002	Pin	1
74	07725102	Magnet	2
75	07037001	Power Unit	1
76	07746004	Switch Unit	1
77	07175003	Housing (L)	1
78	07175004	Housing (R)	1
79	07176001	End Plate	1
80	07746242	Switch	1

Position	Item No.	Description	Pcs.
81	07746241	Switch	1
82	07123650	Spring	1
83	07524441	Pin	2
84	07045227	Hanger	2
85	07123533	Spring	1
86	07123220	Spring	1
87	07452635	Screw	1
88	07452573	Screw	8
89	07469205	Safety Bolt	1

May be subject to changes.

## EC Declaration of Conformity

**We:** **HOLGER CLASEN GmbH & Co. KG**  
**Alsterdorfer Straße 234**  
**DE-22297 Hamburg,**

In accordance with the following Directives

2006/42/EC - The Machinery Directive

2014/30/EU - The Electromagnetic Compatibility Directive

2011/65/EU - RoHS Directive

hereby declare that,

**Equipment:** **Battery-operated Hydraulic Cutting Tool**

**Type:** **CutMax 4**

**Serial number:** \_\_\_\_\_

is in conformity with the applicable requirements of the following documents:

EN 60745-1:2009+A11:2010; EN 60745-2-8:2009

EN 61000-6-4:2007+A1:2011; EN 61000-6-2:2005

I hereby confirm that the equipment named above has been designed to comply with the relevant sections of the above referenced specifications. The unit complies with all applicable Essential Requirements of the Directives.

Hamburg, 11.11.2021

HOLGER CLASEN GmbH & Co. KG

  
Lennart Clasen (Managing Director)